

RIGID STEM AND DISTANT READING Gas Filled Stainless Steel Thermometer

Temperature element
Inert Gas System

Case
AISI 304 Stainless Steel
Bezel Stainless Steel (Bayonet type)
Weatherproof Construction

Dial
White Aluminium (Black Printing)

Pointer
Black Aluminium

Window
Sheet Glass

Standard Size
63, 100, 150mm

Accuracy class
1%

Scale Range
- 200 up to 650deg C.
See standard scale range data sheet

Stem
Stainless Steel.

Stem Dia
6,8,10,12, or 12.7 mm
(standard 12.7 mm)

Capillary
Stainless Steel 1 to 33 mtrs

Ordering information
State:- Temperature gauge model
/ Nominal size / Scale range
/ Stem dia - length / Size of connection
/ Optional extras reqd.

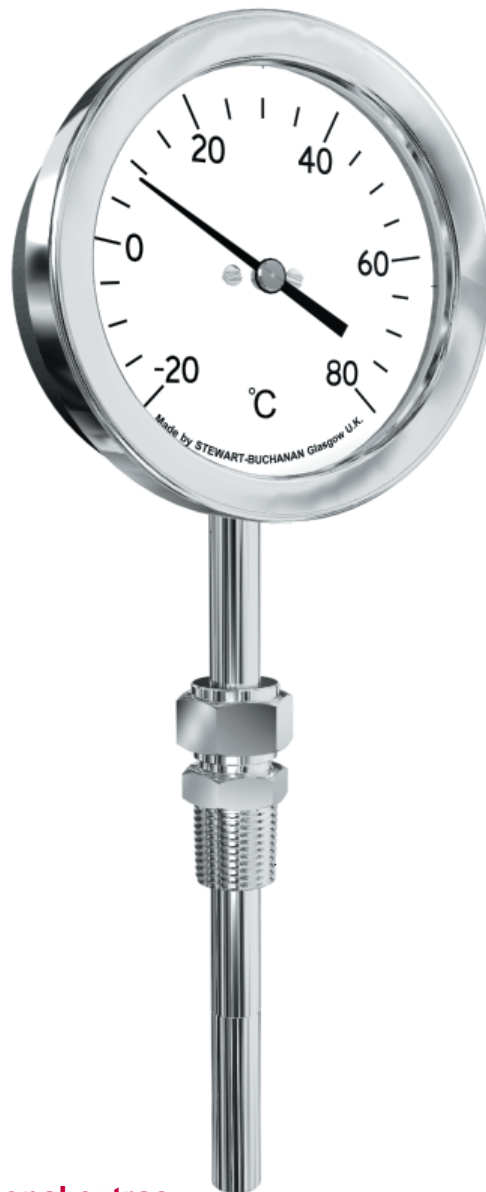

Optional extras

AISI 316 Stainless Steel Case.
Slot adjustable pointer / Black Finish.
Window laminated Safety Glass / Perspex.
Thermowells to user specification.
Standard construction available on request.
Additional Variations: on request.

We manufacture a wide range of instruments to customer's special requirements
We shall be pleased to discuss and advise on your specifications

Specifications and dimensions given in this leaflet represent the state of engineering at the time of printing.
Engineering modifications may take place without prior notice.

STEWART-BUCHANAN GAUGES LTD

Sales Office & Manufacturing Facility.

Burnside Industrial Estate, Kilsyth, G65 9JX, SCOTLAND

Tel:- +44 (0)1236 821533

Fax:- +44 (0)1236 824090

E-Mail:- sales@stewarts-group.com

Web Site:- www.stewarts-group.com

RIGID STEM AND DISTANT READING Gas Filled Stainless Steel Thermometer

Standard Dimensions

Model - 741

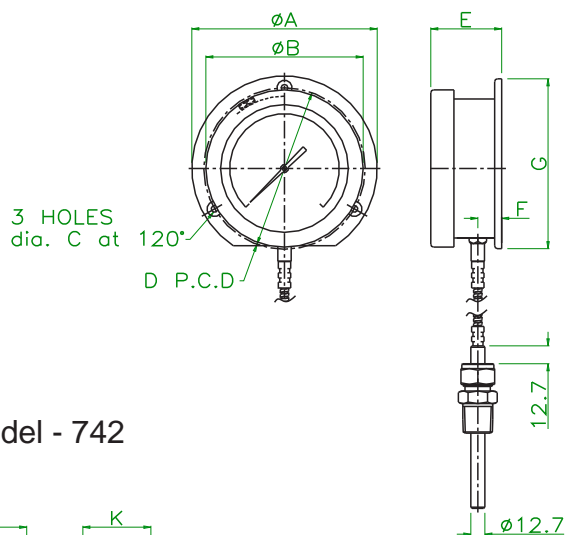

Model - 742

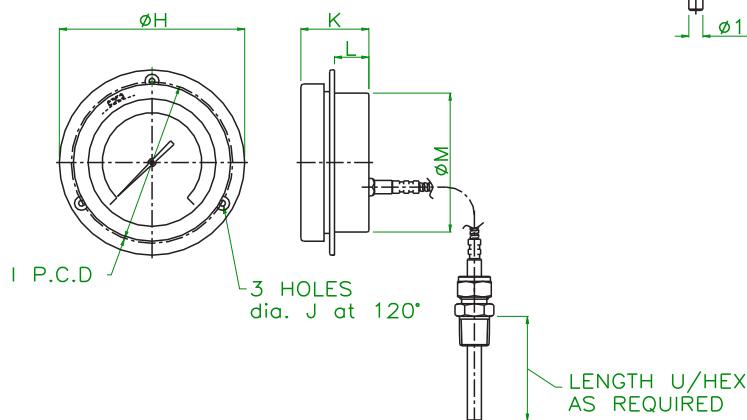

Model - 743

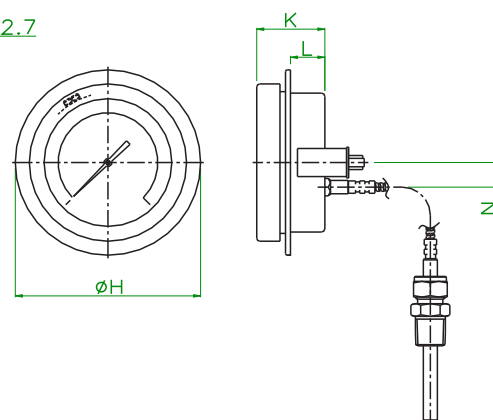

Dimensions Diameter	A	B	C	D	E	F	G	H	I	J	K	L	M	N	Panel Cut-out
63	85	68.5	3.5	75	39	15	78.5	85	75	3.5	37	21.5	62	18.5	66
100	132	112	4.5	116	50.5	19	121	132	116	4.5	48.5	24.5	99	17.5	106
150	185	162	5	168	50.5	19.5	174	185	168	5	48.5	24.5	148	17.5	153

Specifications and dimensions given in this leaflet represent the state of engineering at the time of printing.
Engineering modifications may take place without prior notice.

STEWART-BUCHANAN GAUGES LTD

Sales Office & Manufacturing Facility.

Burnside Industrial Estate, Kilsyth, G65 9JX, SCOTLAND

Tel:- +44 (0)1236 821533

Fax:- +44 (0)1236 824090

E-Mail:- sales@stewarts-group.com

Web Site:- www.stewarts-group.com

RIGID STEM AND DISTANT READING Gas Filled Stainless Steel Thermometer

Standard Dimensions

Model - 852

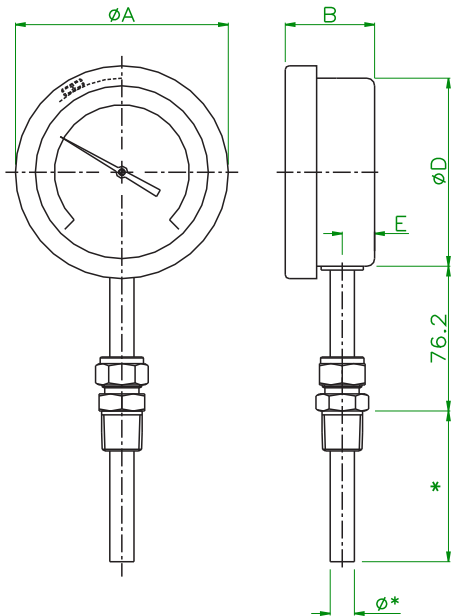

Model - 853

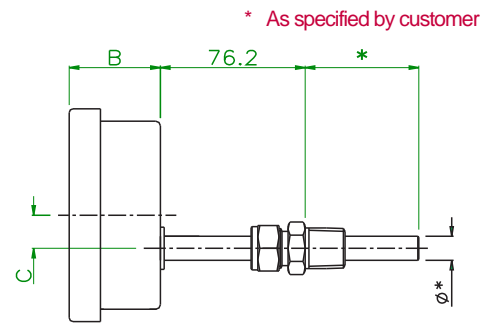

Dimensions Diameter	A	B	C	D	E
63	68.5	37	18.5	62	12
100	112	48.5	17.5	99	17
150	162	48.5	17.5	148	17

Specifications and dimensions given in this leaflet represent the state of engineering at the time of printing.
Engineering modifications may take place without prior notice.

STEWART-BUCHANAN GAUGES LTD

Sales Office & Manufacturing Facility.

Burnside Industrial Estate, Kilsyth, G65 9JX, SCOTLAND

Tel:- +44 (0)1236 821533

Fax:- +44 (0)1236 824090

E-Mail:- sales@stewarts-group.com

Web Site:- www.stewarts-group.com

RIGID STEM AND DISTANT READING Gas Filled Stainless Steel Thermometer

Standard Dimensions

Model - 961

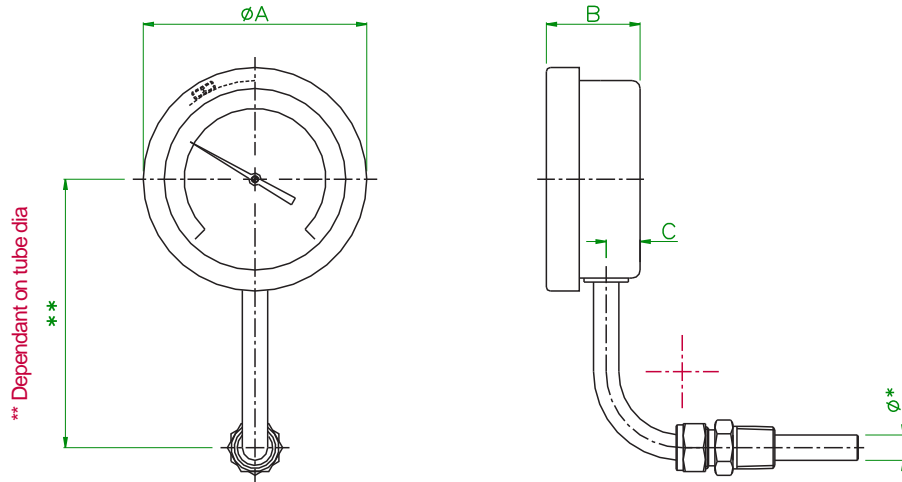

Model - 962

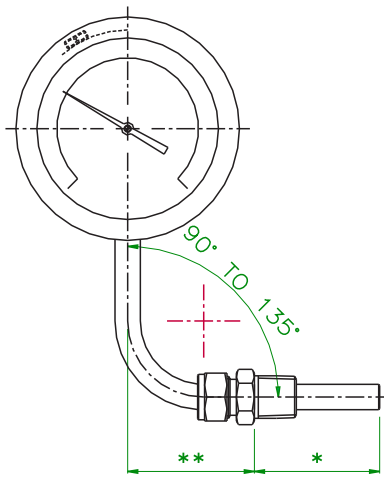

Model - 963

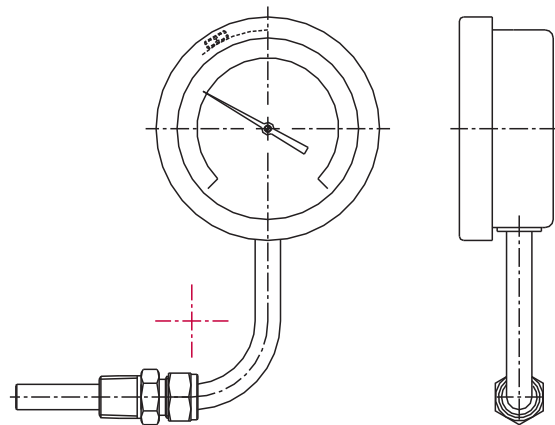

* As specified by customer.
** Dependant on tube dia.

Dimensions Diameter	A	B	C	D
63	68.5	37	18.5	62
100	112	48.5	17.5	99
150	162	48.5	17.5	148

Specifications and dimensions given in this leaflet represent the state of engineering at the time of printing. Engineering modifications may take place without prior notice.

STEWART-BUCHANAN GAUGES LTD

Sales Office & Manufacturing Facility.

Burnside Industrial Estate, Kilsyth, G65 9JX, SCOTLAND

Tel:- +44 (0)1236 821533

Fax:- +44 (0)1236 824090

E-Mail:- sales@stewarts-group.com

Web Site:- www.stewarts-group.com