

WEED INSTRUMENT

INSTRUMENTATION SOLUTIONS FOR INDUSTRY

**SOVEREIGN SERIES
VAPOUR PRESSURE
TEMPERATURE SWITCHES**

S71
ISSUE F

- ▲ Field set point adjustment against a reference scale.
- ▲ SPDT or DPDT switching.
- ▲ Terminal block for easy field wiring.
- ▲ Hermetically sealed microswitch options.
- ▲ Optional gold alloy contacts.
- ▲ 316 stainless steel capillary and bulb.
- ▲ Ranges available up to 260°C (50°F)
- ▲ Weatherproof NEMA 4, IP66 and Explosion proof models.

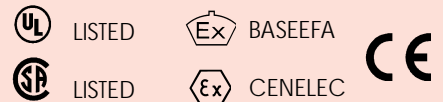
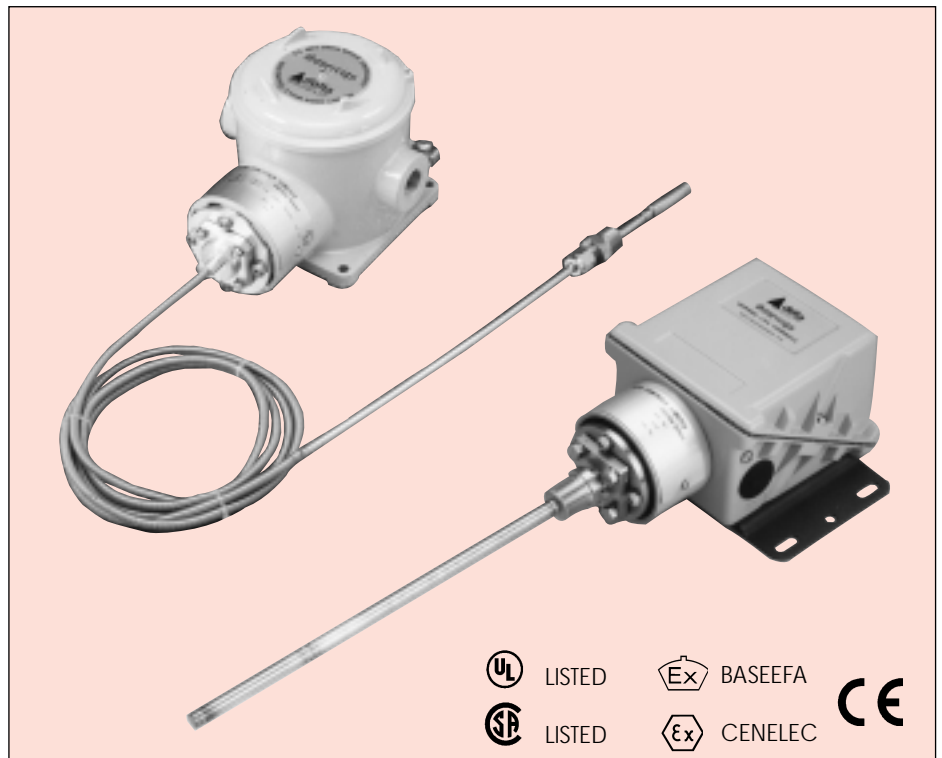

The Sovereign Series S70 Temperature Switches are designed as compact, cost effective solutions to meet a variety of applications in the oil, gas and chemical industries.

May be supplied with either a flexible capillary system terminated in a bendable extension to adapt to various depth thermowells, or rigid stem, both liquid/vapour filled. The set point is fully field adjustable over the specified range. For ease of installation a field wiring terminal block is supplied as standard.

The Sovereign Series continues to offer the high standard of performance and service so long the hallmark of Delta Controls.

HOW TO ORDER

When ordering, please state the relevant product code for each instrument, made up as follows:

Enclosure. See Table 1.	_____	□
Model. See Table 2.	_____	□
Electrical Entry. See Table 3.	_____	□
System Details. See Table 4.	_____	□
Range. See Table 5.	_____	□
Switching Options. See Table 6.	_____	□
Process Connection. See Table 7.	_____	□
Options. See Table 8.	_____	□
Special Engineering.	_____	□

By consultation with our engineers. See Table 9.

ENCLOSURES

FINISH

All enclosures except Type R, A and U are finished in light grey epoxy resin paint. Special finishes to order.

INTRINSIC SAFETY





Temperature switches neither store nor generate electricity and are therefore normally usable in intrinsically safe circuits without further certification provided that the power source of the circuit is certified Exi and the installation is in accordance with the relevant codes of practice (e.g. ANSI/ISA 12.6 or BS 5345 Part 4, 1977). Because of the low voltages and currents of I.S. circuits, we recommend using gold and/or sealed contacts.

NOTE: Codes T and U - To increase Gas Class see Table 6

Enclosures are available that meet the requirements of Japanese Industrial Standards (JIS) for use in hazardous areas. Apply for details.

TABLE 1



EXPLOSIONPROOF ENCLOSURES DIVISION 1 (ZONE 1)	Code
Aluminium Alloy EExd IIC T6(-60 to +65°C), T5(-60 to +80°C) Gravity die-cast enclosure In aluminium-silicon alloy. BASEEFA certified to CENELEC EN 50 014 and EN 50 018. Weatherproof to NEMA type 4, IP66. 	H
For Aggressive Atmospheres EExd IIC T6(-60 to +65°C) T5(-60 to +80°C) Investment cast enclosure In austenitic stainless steel. BASEEFA certified to CENELEC EN 50 014 and EN 50 018. Weatherproof to NEMA type 4X, IP66. 	R
Aluminium Alloy NEC 500, NEMA 7,9 Gravity die-cast enclosure in aluminium-silicon alloy. Class 1, Groups C and D, Class II, Groups E, F and G, Div. 1 & 2. Weatherproof to NEMA type 4, IP66. 	T
For Aggressive Atmospheres NEC 500, NEMA 7,9 CSA Investment cast enclosure in austenitic stainless steel. Class 1, Groups C and D, Class II, Groups E, F and G, Div. 1 & 2. Weatherproof to NEMA type 4X, IP66. 	U
SAFE AREA ENCLOSURES	
General Purpose Weatherproof The basic enclosure is pressure die-cast in zinc alloy, with weather protection not less than NEMA type 4, IP66.	W
Weatherproof For Aggressive Atmospheres Investment cast enclosure In austenitic stainless steel with weather protection not less than NEMA type 4X, IP66.	A

MODELS

TABLE 2





	Code
Fixed Switching Differential. SPDT & DPDT options available. See Table 6. 	S71

ELECTRICAL ENTRY

Adaptors are available for other popular thread sizes

TABLE 3



	Code
Enclosure W: Clearance for 20mm / 3/4in outside dia conduit.	1
Enclosures H, R & A: M20 x 1.5 ISO thread.	0
Enclosures H, R & A: M20 x 1.5 ISO thread, dual entry.	5
Enclosures H, R, T & U: 3/4-NPT INT. 	3
Enclosures H, R, T & U: 3/4-NPT INT. dual entry 	6
Enclosure W: M20 x 1.5 elbow adaptor.	0

 SEE APPROVALS

SYSTEM DETAILS

The flexible capillary version of Series S70 comprises an armoured capillary attached to the sensing bulb via a semi-rigid extension on which a 1/2" NPT compression gland slides to enable various depths of thermowell (pocket) to be accommodated. All exposed parts of the thermal system are in 300 series austenitic stainless steel with the capillary and sensing bulb in 316 stainless steel.

SETTING RANGES

Ranges Q6 and U5 (QC and UA) cannot be used on rigid stem models (system code R). Limitation due to conduction causing an unacceptable rise in surface temperature. See Table 1.

When ordering, please state units required. Range and set point will be in units of preference. Unless otherwise stated units will be in °C.

T_{max} = maximum working temperature

TABLE 4

Capillary Length		Semi Rigid Stem Length		Sensing Bulb Length		Code
Metres	Feet	mm	inches	mm	inches	
1.86	6	250	10	75	2.95	N
1.86	6	500	20	75	2.95	P
Rigid Stem Probe Total Length 216mm (8.5ins)				75	2.95	R

 APPLIES TO ALL DETAILS IN THE TABLE ABOVE

The rigid stem version has an integral thread for direct mounting or via a thermowell. Material of probe 316 stainless steel.

NOTE: Bulb diameter, all ranges 9.5mm 0.37 inches.

TABLE 5a °C

T_{max}	RANGE		Code
70	-40	to +60	H1
110	0	to 100	K3
200	110	to 190	Q6
270	160	to 260	U5

TABLE 5b °F

T_{max}	RANGE		Code
158	-40	to +140	HA
230	32	to 212	KB
392	230	to 374	QC
518	320	to 500	UA

 APPLIES TO ALL RANGES IN TABLE ABOVE

SWITCHING OPTIONS

TABLE 6

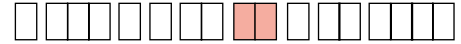

Model S71										
UL/CSA RATING (RESISTIVE) §SEE NOTE	IEC 947-5-1/EN 60947-5-1 RATING								Contact	Code
	Designation & Utilization Category		Rated operational current I_e (A) at rated operational voltage U_e	U_i	U_{imp}	VA rating				
						Make	Break			
5 Amps @ 110/250V AC Light Duty for AC only	AC14 DC13	D300 R300	0.6/0.3A @ 120/240V AC 0.22/0.1A @ 125/250V DC	250V	0.8kV	AC DC	432 28	72 28	SPDT DPDT	00 01
5 Amps @ 110/250V AC and 2 Amps @ 30V DC General purpose precision	AC14 DC13	D300 R300	0.6/0.3A @ 120/240V AC 0.22/0.1A @ 125/250V DC	250V	0.8kV	AC DC	432 28	72 28	SPDT DPDT	02 03
1 Amp @ 125V AC and §100 mA @ 30V DC gold alloy contacts for low voltage switching	1A @ 125 VAC RESISTIVE (IEC 1058-1/EN 61058-1)								SPDT DPDT	04 05
§5 Amps @ 110/250V AC and 5 Amps @ 30V DC Environmentally sealed	AC14 DC13	D300 R300	0.6/0.3A @ 120/240V AC 0.22/0.1A @ 125/250V DC	250V	0.5kV	AC DC	432 28	72 28	SPDT* DPDT*	08 09
§1 Amp @ 30V AC and 30V DC Environmentally sealed with gold contacts	AC14	E150	0.3A @ 120V AC	125V	0.5kV	AC	216	36	SPDT* DPDT*	0G 0H
5 Amps @250V AC and 2 Amps @ 30V DC Hermetically sealed. Gold plated silver contacts	AC14 DC13	D300 R300	0.6/0.3A @ 120/240V AC 0.22/0.1A @ 125/250V DC	250V	0.5kV	AC DC	432 28	72 28	SPDT DPDT	H2 H3†, H6‡

†1 Single pole, double throw, simultaneous falling under temperature.
‡2 Single pole, double throw, simultaneous rising under temperature.

NOTE: Enclosure Codes T and U.
Microswitch Codes 02 and 03.
UL/CSA rating as follows:-
110/150V AC 5A 250V/125V DC 0.25/0.5A

Enclosure Codes H and R.
Microswitch Codes 02 and 03.
UL/CSA Rating as follows:-
110/250V AC 5A 250V/125/30V DC 0.25/0.5/2A

NOTE: Using Codes H2, H3, H6 increases the Gas Class to:
Class 1, Groups A, B, C and D, Div 2., for Enclosures T and U.



UL recognised component for use in hazardous areas.
Class 1, Div 2, Groups A,B,C and D. Class II Groups E,F
and G. When used in enclosures T and U.



CSA accepted component for use in hazardous areas Class 1, Div 2, Groups A,B,C and D.
When used in enclosures T and U.

The electrical rating is dependent on the microswitch fitted to the instrument. The electrical ratings defined by each approval that the micro switch complies with and is shown on the product nameplate, ie UL/CSA, or IEC. It should be noted that the instrument must be used within the electrical rating specified from the approval you require. This table lists the actual IEC ratings against the Designation & Utilization Category marked on the nameplates. In the absence of any verification by UL/CSA the microswitch §manufacturer's rating is stated in **italics and bold**.
If in doubt seek guidance from the factory.

NOTE: For low energy circuits e.g. 30V and up to 100mA, we recommend using gold alloy contact switches.
 U_i = rated insulation voltage: U_{imp} = rated impulse withstand voltage across contacts.

PROCESS CONNECTION

TABLE 7



	Code
1/2 - 14 NPT EXTERNAL Sliding Gland (System Code N, P)	E
1/2 - 14 NPT EXTERNAL Direct Mounting (System Code R)	J



APPLIES TO ALL PROCESS CONNECTIONS IN TABLE ABOVE

OPTIONS AND TREATMENTS

Combinations available, apply for details.

TABLE 8

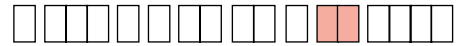

	Code
Tropicalisation High humidity environment.	01
Marine and Offshore Saline atmosphere or salt spray.	02
Ammonia Process (wetted) parts and construction suitable for atmospheric ammonia.	03
Oxygen Service 2: Process (wetted) parts are cleaned for oxygen.	04
Oxygen Service 3: Process and non process parts are cleaned for use with oxygen.	05
Stainless Steel Pipe Mounting Bracket Permits local 2" pipework to be utilised for mounting the instrument.	10
Tagging - Variety of tagging methods are available	APPLY FOR DETAILS
Applies when - no option is required and selection is made from special engineering	00
PVC covered armoured capillary	40

APPLIES TO ALL OPTIONS AND TREATMENTS IN TABLE ABOVE

SPECIAL ENGINEERING

To your individual requirements, where specified.

For your convenience, enter your special listing in spaces provided.

TABLE 9



FEATURE	Code

REFER TO ENGINEERING

PERFORMANCE DATA

FIXED SWITCHING DIFFERENTIAL

Figures given in Table 10 are typical maxima for mid-range setting and are for guidance only. Values will vary across the range, i.e. lower at the bottom and higher at the top of the range. Should the differential be critical for specific applications our engineers should be consulted prior to ordering.

TABLE 10

CELCIUS UNITS

Range		T max °C	Model	MICROSWITCH - OPTION SWITCHING DIFFERENTIAL °C									
Code	°C			00	01	02	03	04	05	08/0G	09/0H	H2	H3/H6
H1	-40 to +60	70	S71	1.5	2.5	2	4	1.5	3	6	6	8	10
K3	0 to 100	110	S71	1.5	2.5	2	4	1.5	3	6	6	8	10
Q6	110 to 190	200	S71	1.5	2.5	2	4	1.5	3	6	6	8	10
U5	160 to 260	270	S71	1.5	2.5	2	4	1.5	3	6	6	8	10

FARENHEIT UNITS

Range		T max °F	Model	MICROSWITCH - OPTION SWITCHING DIFFERENTIAL °F									
Code	°F			00	01	02	03	04	05	08/0G	09/0H	H2	H3/H6
HA	-40 to +140	158	S71	2.7	4.5	3.6	7.2	2.7	5.4	10.8	10.8	14.4	18
KB	32 to 212	230	S71	2.7	4.5	3.6	7.2	2.7	5.4	10.8	10.8	14.4	18
QC	230 to 374	392	S71	2.7	4.5	3.6	7.2	2.7	5.4	10.8	10.8	14.4	18
UA	320 to 500	518	S71	2.7	4.5	3.6	7.2	2.7	5.4	10.8	10.8	14.4	18

TECHNICAL DATA

ACCURACY

Set point repeatability $\pm 1\%$ of span at 20°C ambient.

AMBIENT TEMPERATURE RANGE

Certified Enclosures - Refer to Table 1 for limitations of use.

Operation

Ranges H1, K3 and Q6 are suitable for operating within a range of ambient temperature from -60 to +80°C (-76 to +176°F).

Range U5 cannot be used in ambient temperatures below -25°C to avoid filling medium freezing.

CAUTION:

Moving parts have been treated with a water repelling lubricant before leaving factory.

Occasional inspection and the application of a water repelling lubricant is recommended to ensure moving parts remain free under all conditions.

WARNING: Does not apply to Oxygen Services, see Table 8.

ELECTRICAL CONNECTIONS

Terminal block

Cable entry is to a non-pinching terminal block made of a non-hygroscopic thermosetting plastic, suitable for cables up to 2.5mm²/14AWG.

Earthing/Grounding

An earthing facility is provided.

Dielectric Strength

The electrical assembly is capable of withstanding *2kV between live parts and earth/ground and 500V between open contacts.

*1.2kV for microswitch Codes H2, H3 and H6. Refer to Table 6.

Electrical Entry

Standard options are listed in Table 3. Pg. and ET threads can be accommodated by adaptors. Dual entry available in some enclosures. See Table 3.

MAXIMUM WORKING PRESSURE

System sensing probes for both the capillary and rigid stem version will withstand 100 bar (1500 psi) without need for a thermowell.

UNIT WEIGHTS (Approx.)	
'H', 'T' enclosures	2.6kg/5.7lb
'R', 'U' enclosures	7.1kg/15.6lb
'W' enclosure	2.6kg/5.7lb
'A' enclosure	3.9kg/8.6lb

OPERATION/ INSTALLATION

Mounting Position/Location/ Installation

Vertical as shown, taking care to avoid siting in locations that transmit excessive shock or vibration. For further advice contact our engineers.

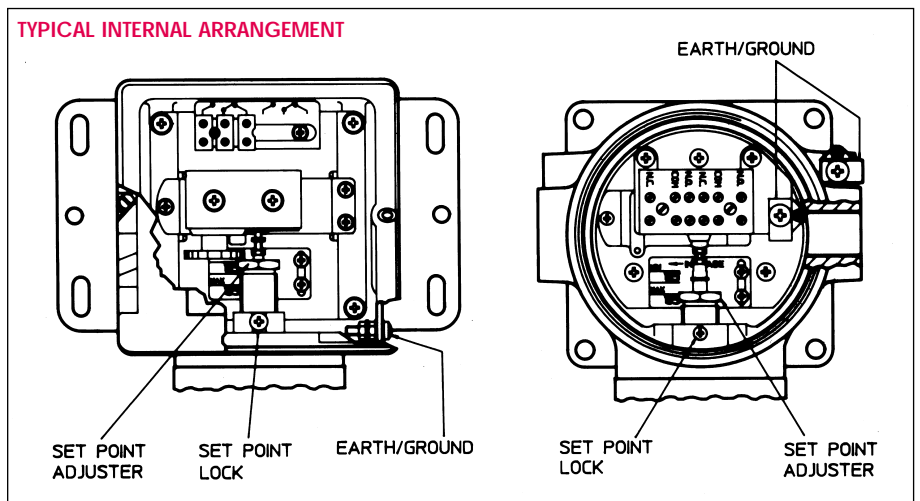

THERMOWELLS

Material 316SS
Maximum Working Pressure 140 bar (2000 psi) at 20°C.

Thermowells can also be manufactured to customers own drawings/ specification requirements.

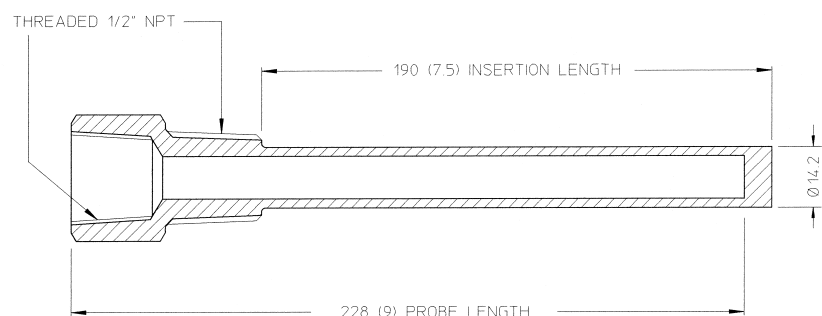

ALL DIMENSIONS mm (inches)

APPROVALS

CENELEC/BASEEFA



BASEEFA certified to CENELEC EN50 014 and EN50 018.
for use in Zone 1 hazardous areas.

Enclosure Codes H and R and all models.
BASEEFA No. Ex 89C 1374

CANADIAN STANDARDS ASSOCIATION



Switches - Automatic - Pressure Type - For hazardous locations
Enclosure codes T & U

Class 1 Groups C & D, Class II Groups E F and G
LR 94185-2

UNDERWRITERS LABORATORIES INC.



NOWT
Float - and Pressure - Operated Motor Controller
For Use in Hazardous Locations.

E136771(N)
Enclosure codes T & U

Class 1. Groups C and D, Class II, Groups E, F and G.

DIMENSIONS

'W' ENCLOSURE

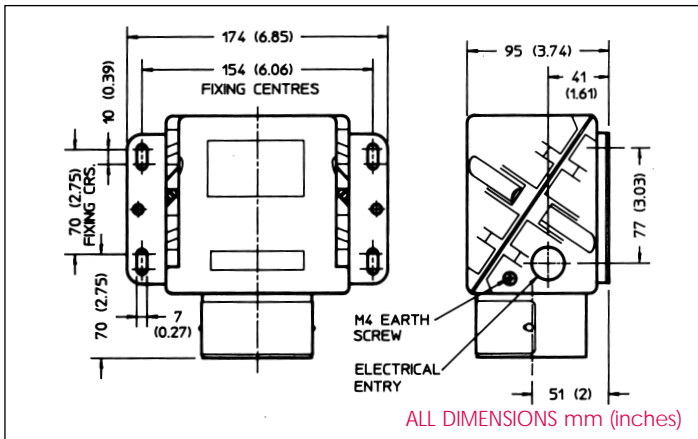

'A' ENCLOSURE

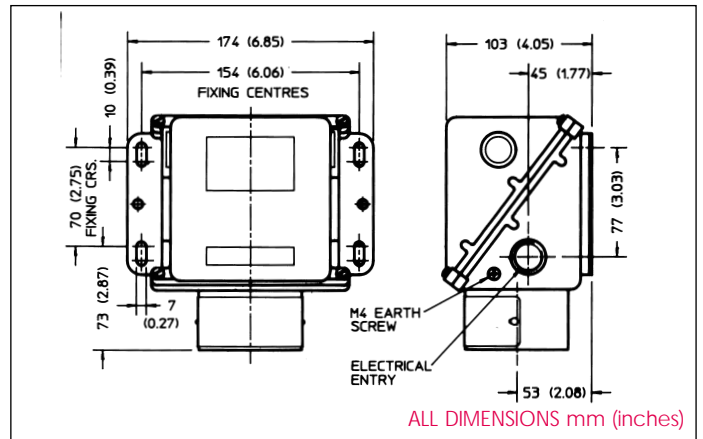

'H', 'R', 'T', 'U' ENCLOSURES

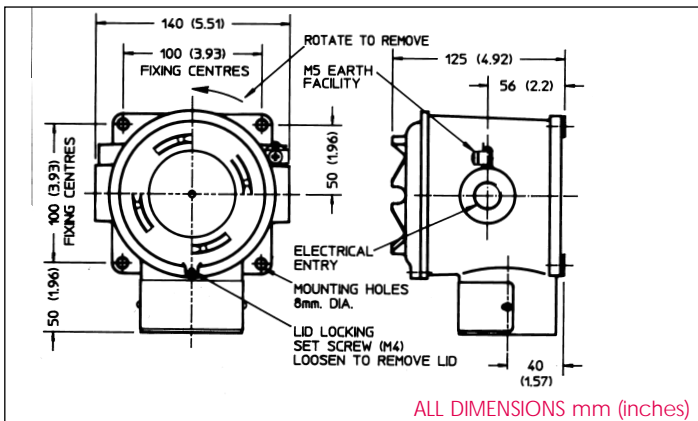

DIMENSIONS

RIGID STEM VERSION - CODE R

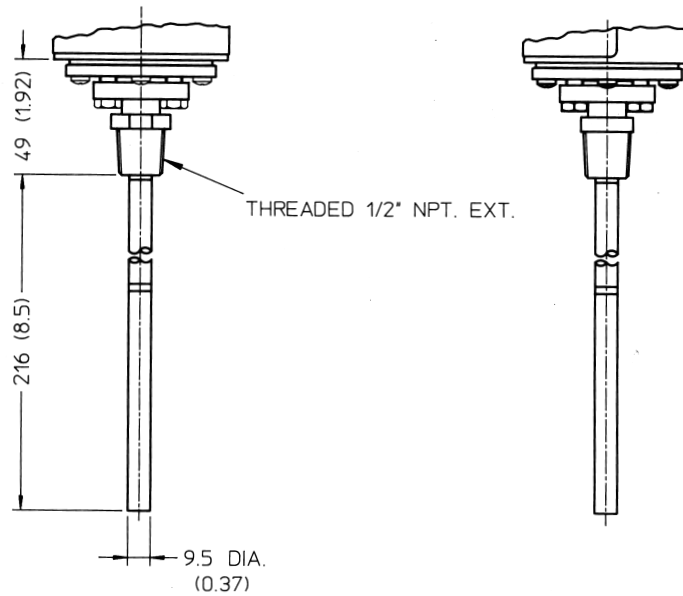

CAPILLARY VERSION - CODES N & P

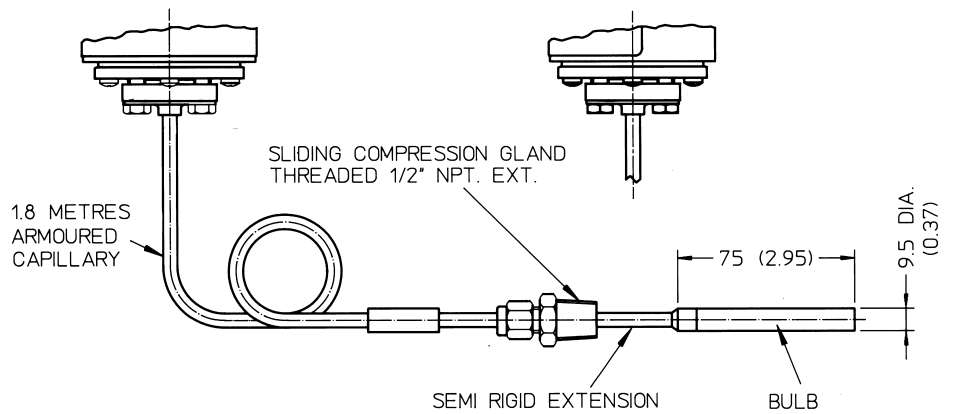

In the interest of development and improvement Delta Controls Ltd, reserve the right to amend, without notice, details contained in this publication. No legal liability will be accepted by Delta Controls Ltd for any errors, omissions or amendments.



DELTA CONTROLS LIMITED, ISLAND FARM AVENUE, WEST MOLESEY, SURREY KT8 2UZ
TEL: +44 (0)20 8939 3500 FAX: +44 (0)20 8783 1163
E-MAIL: sales@delta-controls.com WEB SITE: www.delta-controls.com

Registered Office Registered in England No. 486464

STOCK NO: 002521/S71 - Nov '99

